

1- HEATED SPACE

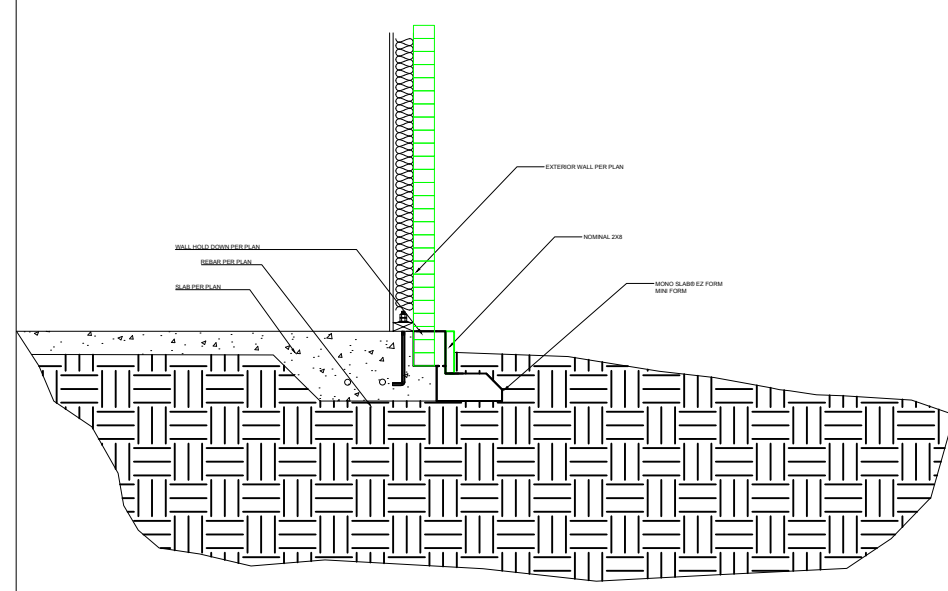

2- UNHEATED SPACE

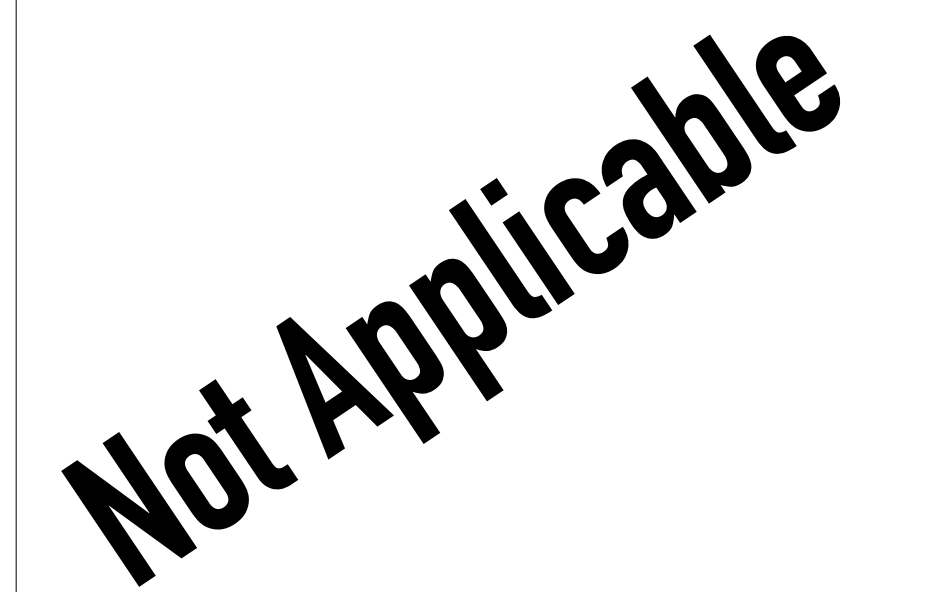

3- GARAGE STEP DOWN

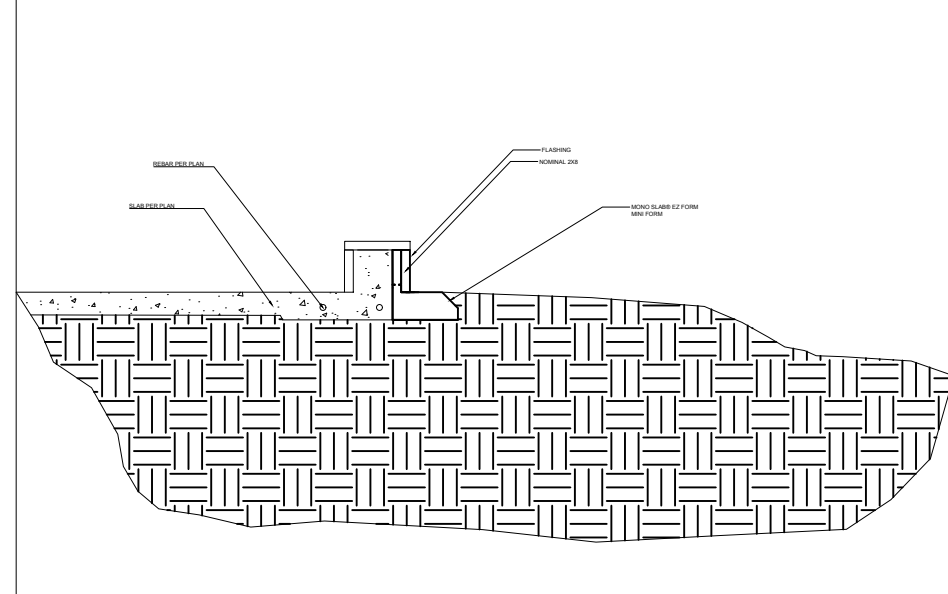

4- DRIVEWAY APPROACH

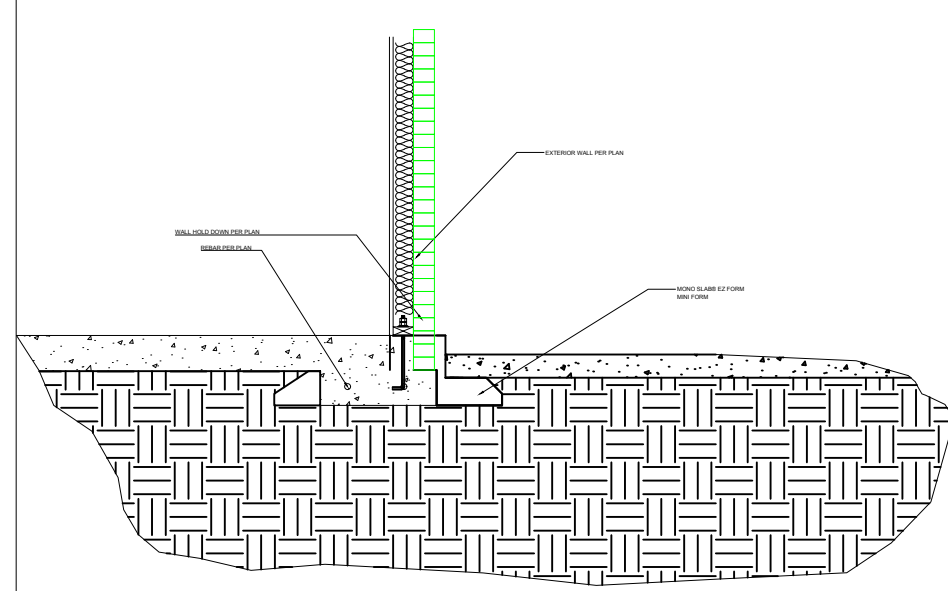

5- BRICK LEDGE

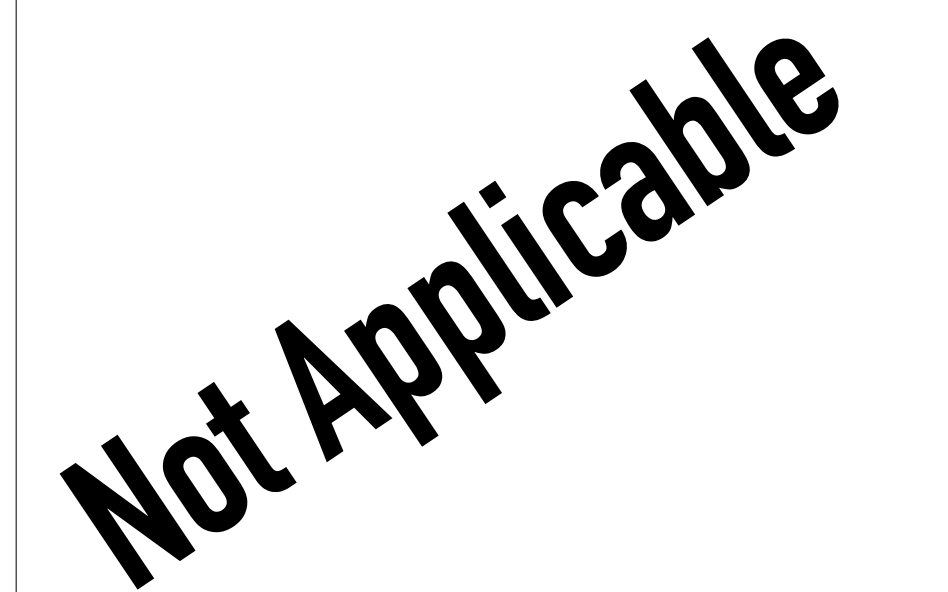

6- EXTERIOR CORNER

Not Applicable

7- INSIDE CORNER

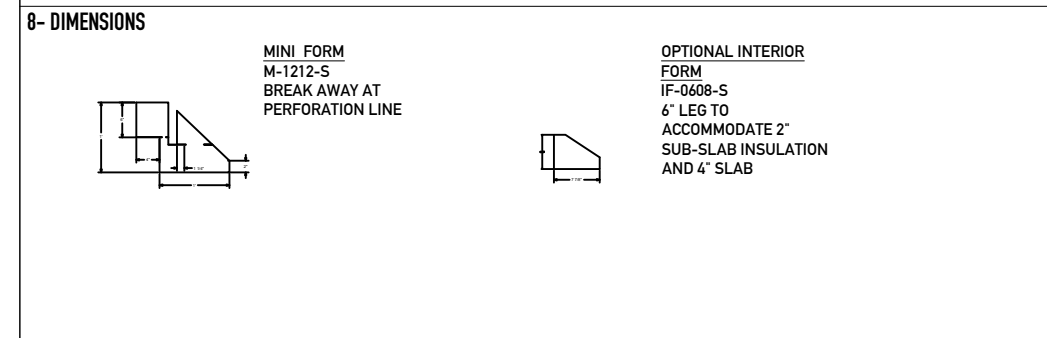
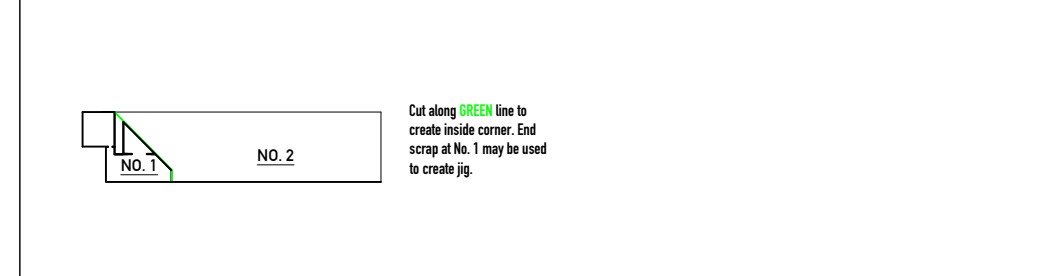

9- GARAGE TO HOUSE

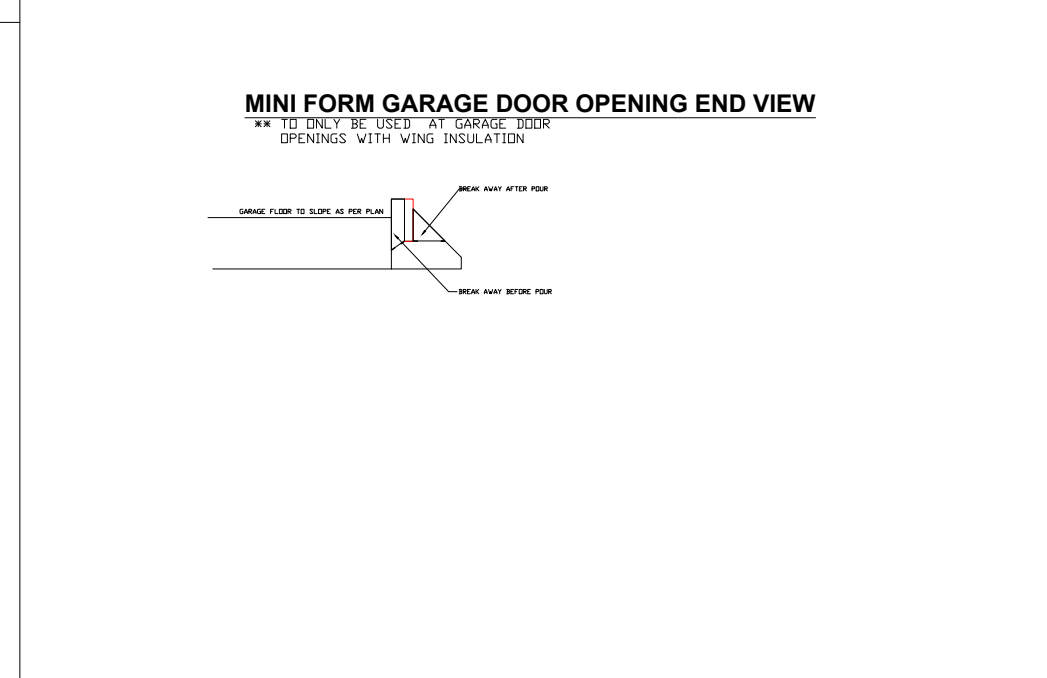
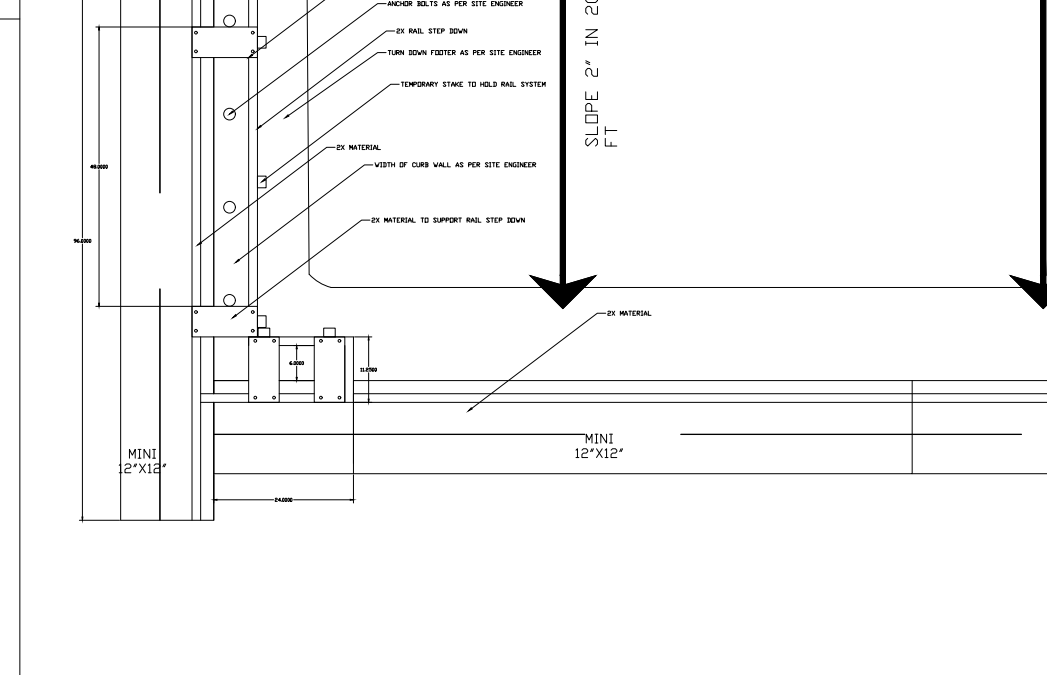
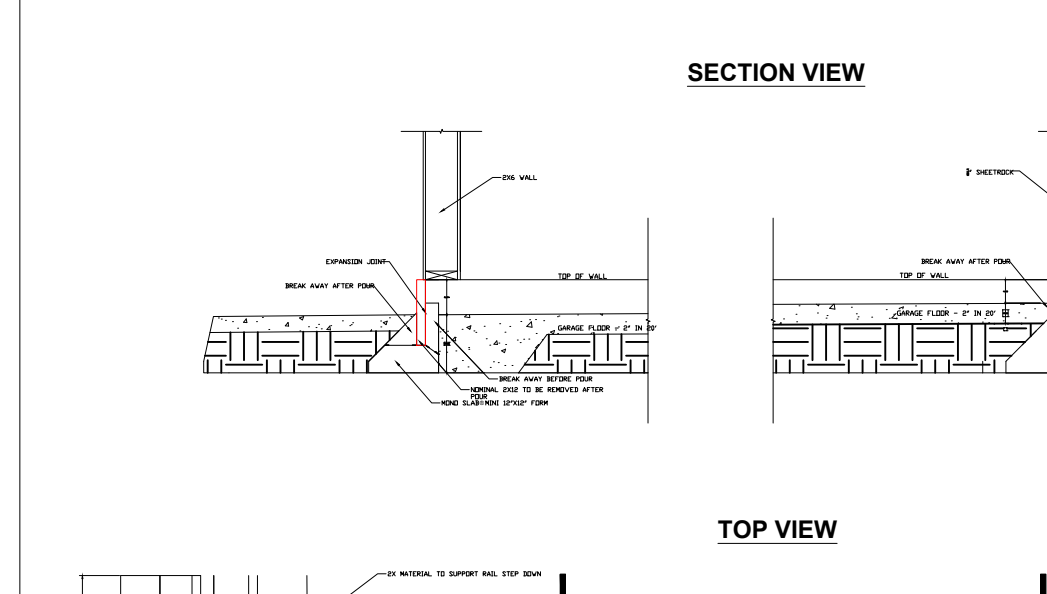

10- STEP DOWN

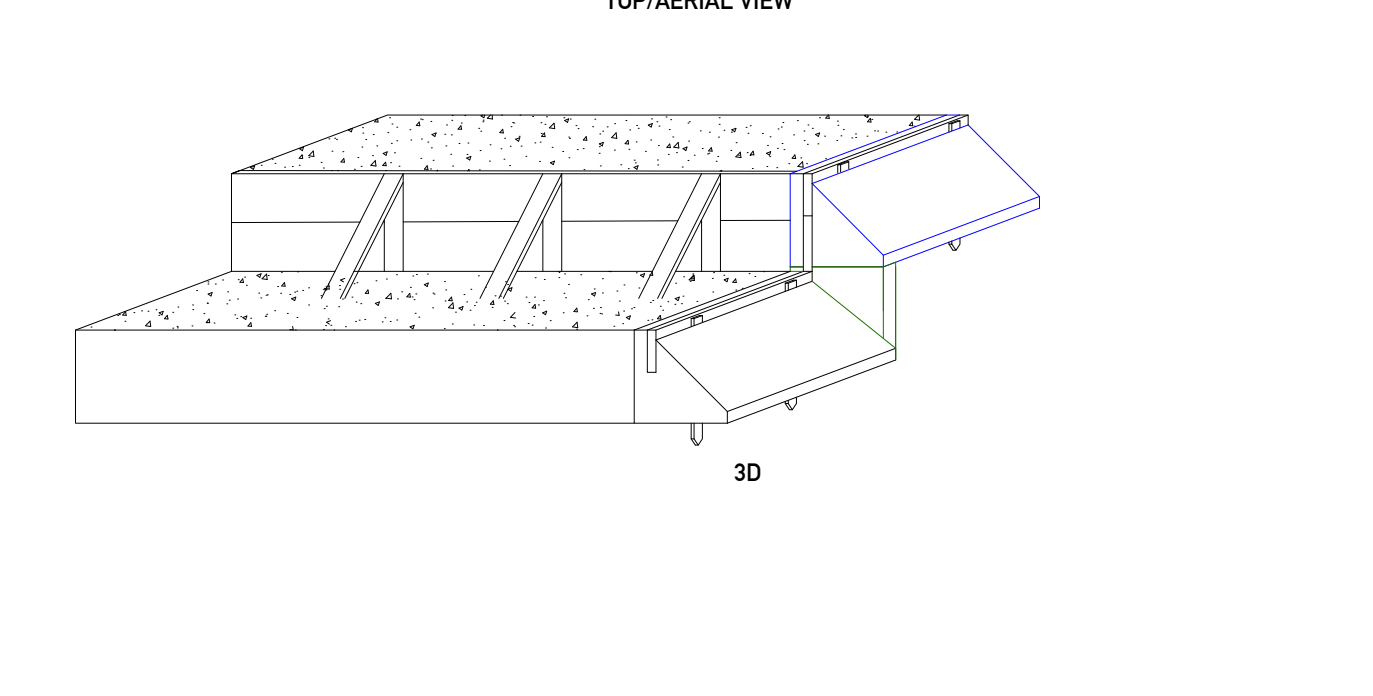
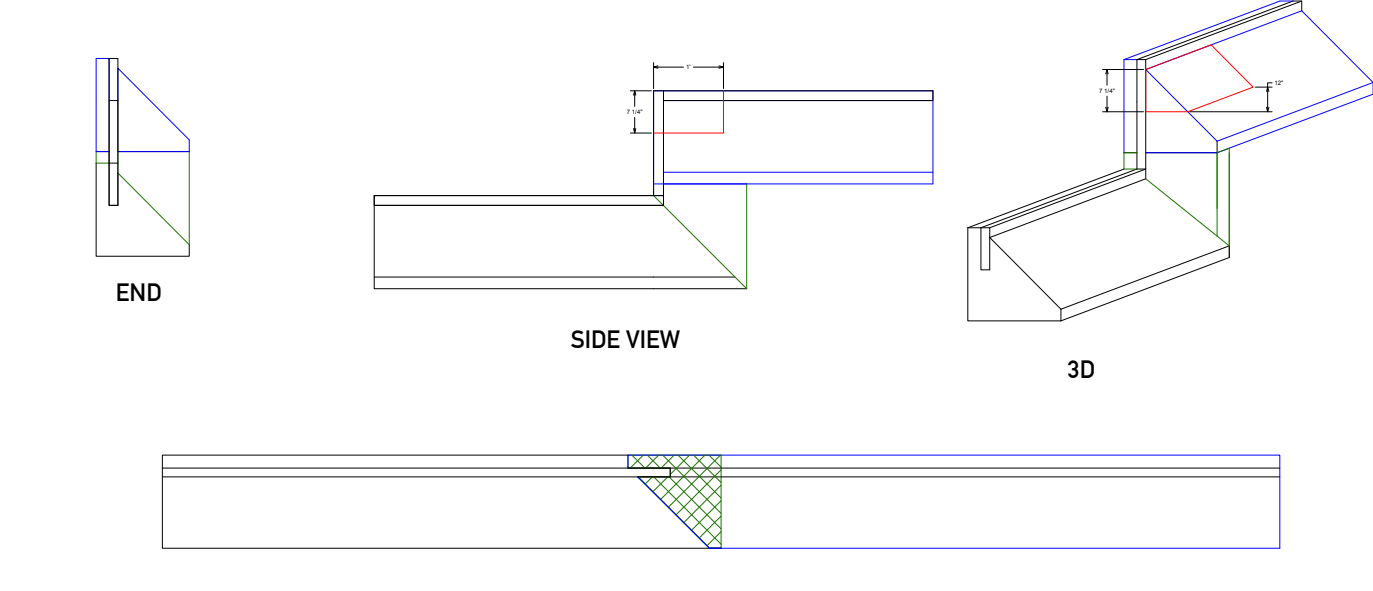

11- FLASHING

Not Applicable

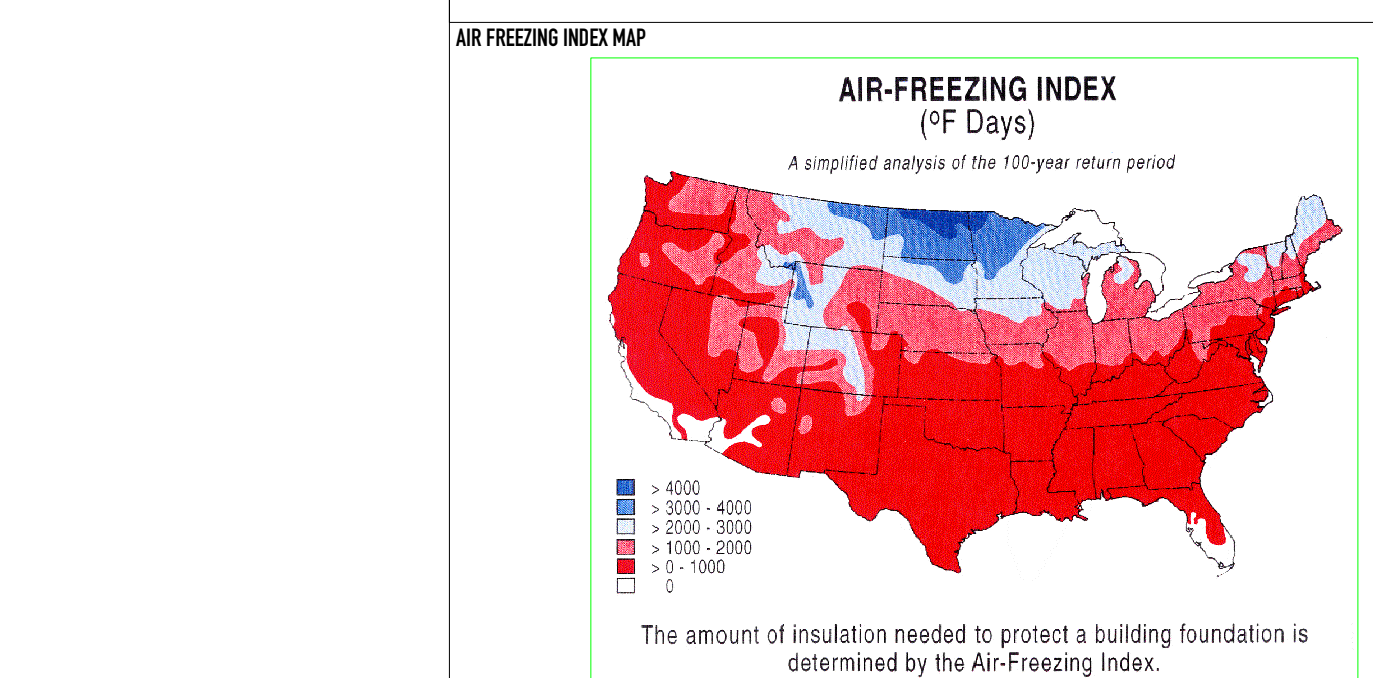

NOTE:
NO. 9-12 ARE GENERALIZED DRAWINGS. NO 9-12 CONSULT STRUCTURAL ENGINEER FOR SITE SPECIFIC SIZING

US PATENT NO. 10, 024, 023 US PATENT NO. 10, 024, 024 PATENT PENDING

WWW.MONOSLABEZFORM.COM
208558-5200

12- POINT LOAD FOOTER / SPOT FOOTER / PAD FOOTER

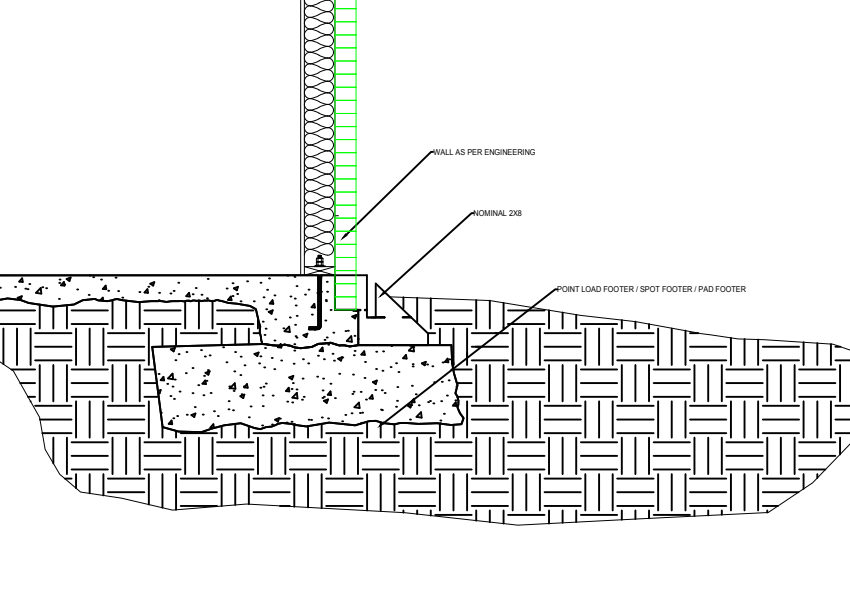

13- POST TENSION

Not Applicable

14- MONO SLAB® EZ FORM INSTALLATION

Not Applicable

MONO SLAB® EZ FORM DETAILS MBL-1212-S

US PATENT NO. 10, 024, 023 US PATENT NO. 10, 024, 024 PATENT PENDING
PO BOX 371 ISLAND PARK, ID 83429 208-558-5200 WWW.MONOSLABEZFORM.COM